

Harbor

AGF studio

HANDBAG DESIGNED BY AGF STUDIO



FABRICS DESIGNED BY Sharon Holland



CTL-49904
TROPICAL BRONZE



CTL-59903
NETTING STRING



PE-440
MACCHIATO

FABRIC REQUIREMENTS

Fabric A	CTL-49904	1 FQ.
Fabric B	CTL-59903	5/8 yd.
Fabric C	PE-440	5/8 yd.

ADDITIONAL MATERIALS

- Faux Tan Leather
- Two (2) 1 1/2" Silver Rings
- One (1) Magnetic Snap
- Annie's Soft and Stable (white)
- Drafting Paper
- Scissors
- Ruler

CUTTING DIRECTIONS

From Faux Tan Leather

- One (1) 1 1/2" x 15" strip (Magnetic Snap Strip)
- Two (2) 5" x 6" rectangle (Strap Extenders)
- One (1) 6" x 32" strip (Strap)



DRAFTING THE PATTERN

- Take a large sheet of drafting paper and draw a 15" x 18" rectangle. (Diagram 1)

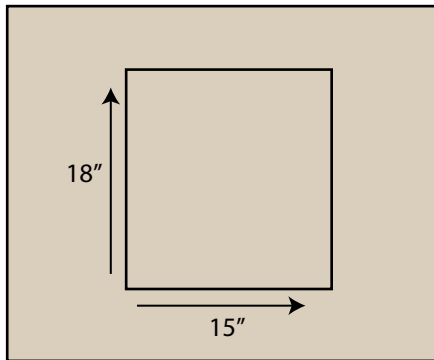

DIAGRAM 1

- Measure and mark 2" over from the top of your rectangle and 4" over at the bottom of your rectangle. Connect marks with ruler, making a diagonal line.
- Repeat this same process on the other side of your rectangle. (Diagram 2)

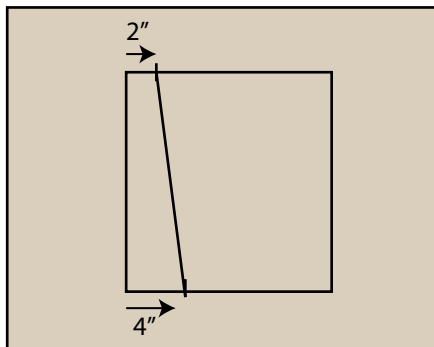

DIAGRAM 2

- Add 1/2" to each side of your rectangle cut out pattern pieces. (Diagram 3)

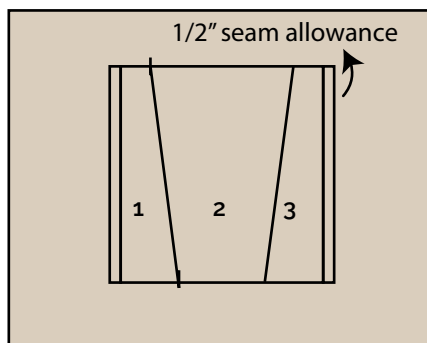

DIAGRAM 3

CONSTRUCTION

- Cut out Pattern 2 in Fabric **A**
- Cut out pattern 1 and 3 in Fabric **B**
- Sew Pattern pieces 1-3 together at 1/4" following Diagram 4. Press seams toward Fabric **A**.
- Use sewn piece as a template to cut out backing piece in Fabric **B**, two lining pieces in Fabric **C** and two pieces of Annie's Soft and Stable.
- Trim tops of lining pieces 1/4" so the lining will lay nice and flat on the interior of your bag when finished.

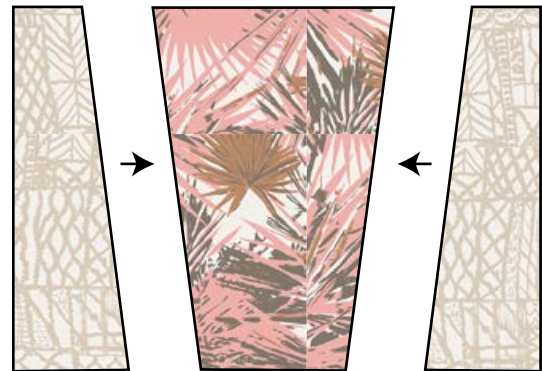
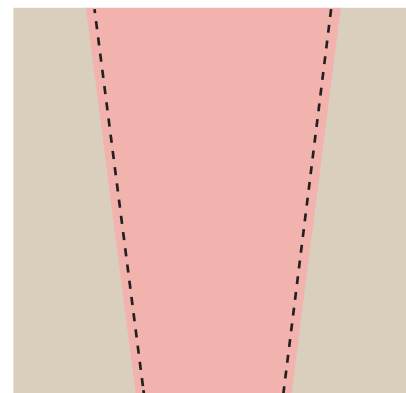

DIAGRAM 4

- Topstitch front of bag to Anne's Soft and Stable following Diagram 5.
- To attach your soft and stable to your back bag place rectangle from Fabric **B** on top of soft and stable and sew all the way around your piece at 1/4" (Diagram 6)



Topstitch

DIAGRAM 5

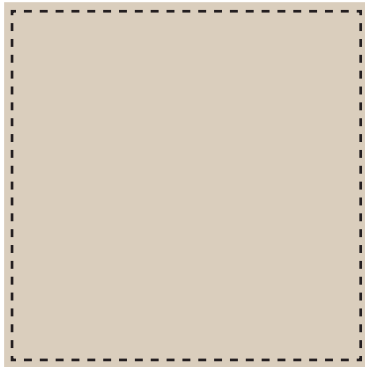

DIAGRAM 6

- Take the front and back bag and sew right sides together sewing the sides and bottom of your bag. Repeat this same process with your lining pieces but leave a small unsewn portion at the bottom in order to pull right side of bag through.

BOX CORNERS CONSTRUCTION

- We want to box the interior corners to get a really nice flat bottom on the bag; this way the bag will have more body.
- Take the exterior of the bag (wrong side out) and pinch apart the two layers of the bag to get a little triangle on one corner. Flatten it down a little bit and make sure the top and bottom seams are lined up. Hold it tight.
- Place the bag flat on the table. Take the acrylic ruler with the 45° angle and lay it on the corner so that the 45° line is right on the edge of the triangle corner.
- We want to do a 2" gusset for this bag, so draw a line 2" long (with the air-erasable marker) right across the bottom of the 45° corner.
- Stitch on top of the marked line. Trim excess fabric if desired, or leave it to add more body to the corner.
- Repeat these steps for the other tote corner and for both lining corners as well.

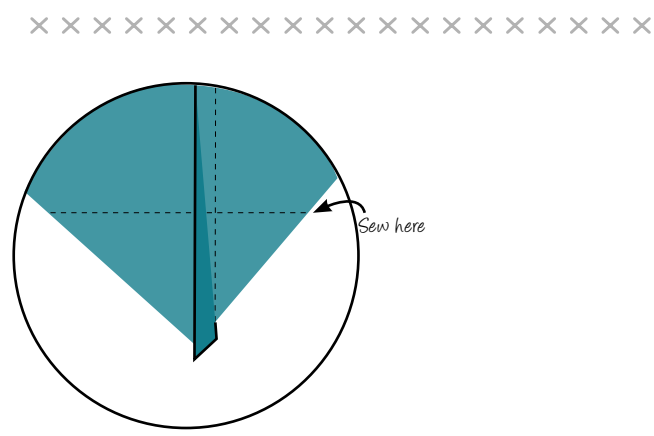

DIAGRAM 7

Applying a Magnetic Snap

- **Note:** A magnetic snap has two main components, a male side & a female side. The magnetic snap also comes with a backing washer for each component. When you purchase a magnetic snap, you will receive 4 metal pieces in total.
- Fold your 1 1/2' x 15" strip from Faux Tan Leather in half with short ends together. Mark the midpoint. From the midpoint measure 1 1/2' up and mark on wrong side of the fabric. This is the piece you are going to add the male side of the magnetic snap. (Diagram 8)
- Place a washer on the wrong side of the fabric on your mark. Mark with a pencil two lines, from top and bottom tracing inside the rectangles on the washer. (Diagram 9)

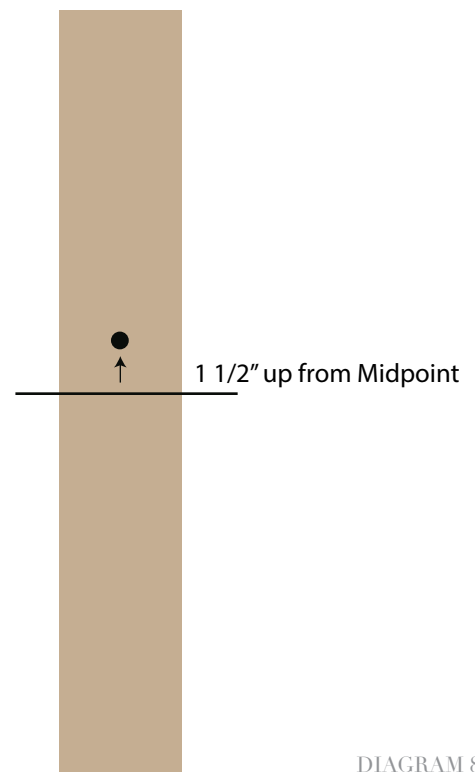

DIAGRAM 8

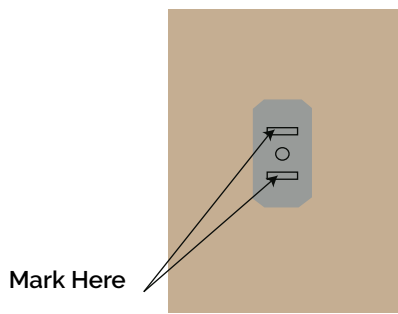

DIAGRAM 9

- Remove the washer and make two slits on those marks using a small pair of sharp scissors.
- Place the arms of the male magnetic snap through the slits from the right side of the piece.

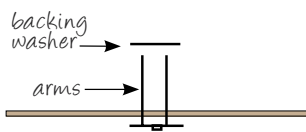

DIAGRAM 10

- Put the washer over the arms from the wrong side of the fabric.
- Using pliers, fold each arm of the snap out and down in opposite directions around the washer. Make the arms as flat as possible.

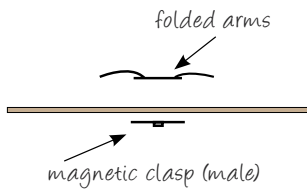

DIAGRAM 11

- Fold strip with magnetic snap on it in half with short ends touching and wrong side of fabric touching. Topstitch the sides and bottom of your strip as close the edge as possible. (Diagram 12)
- Find the top midpoint of your back bag and stitch magnetic snap in place. (Diagram 13)



DIAGRAM 12



DIAGRAM 13

- Find the top midpoint of your front bag and measure down about 4 1/2", this is where you will attach the female side of your magnetic snap. Repeat the same process in Diagram 9-11 with the female side of the magnet.

Creating the Strap and Strap Extenders

- Take your 6' x 32" strip from Faux Tan Leather and fold each long side of your fabric in to the middle of your piece. Then fold in half. Topstitch both sides of your strap at 1/8". (Diagram 14.1-14.3)
- Repeat this same process with your 5' x 6" rectangle from Tan Faux Leather but fold the 5" sides in towards the middle and then fold in half.

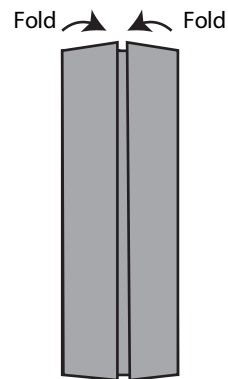

DIAGRAM 14.1

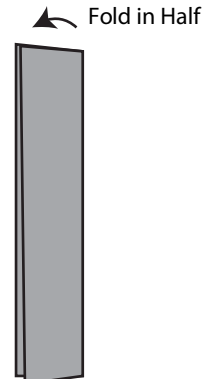

DIAGRAM 14.2

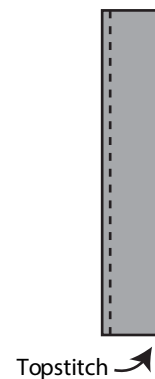

DIAGRAM 14.3

- Thread the strap extenders through a 1 1/2' circle ring and stitch ends to secure circle ring. (Diagram 15)
- Repeat with other strap extender and circle ring.

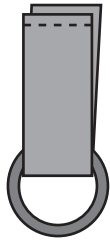

DIAGRAM 15

- Line up end of strap extenders to each side seam and stitch at 1/4' to stitch into place. (Diagram 16)

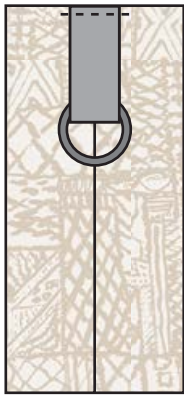

DIAGRAM 16

- Tuck the exterior of the bag into the lining. Right sides of the lining and exterior of the bag should be facing each other. Pin lining and exterior of bag together. Sew around top of bag at 1/2'. Flip right side of the bag through the unsewn portion in the lining.
- Fold under raw edges and hand stitch or machine stitch unsewn portion in lining closed.
- Tuck lining inside of bag and topstitch 1/4' all the way around the top of your bag.
- Next take each end of your straps and thread it through the circle rings and pull through 2 1/2' and topstitch a box with an X in it to secure strap to circle ring.

XX

*Congratulations
& enjoy*

XX



artgalleryfabrics.com

NOTE: While all possible care has been taken to ensure the accuracy of this pattern, We are not responsible for printing errors or the way in which individual work varies. Please read instructions carefully before starting the construction of this quilt. If desired, wash and iron your fabrics before starting to cut.