

# Au Revoir Tote

artgalleryfabrics.com



Featuring

*Chérie*

Collection  
by Frances Newcombe



## Fabric Requirements

Fabric A	CHE-8808	2/3 yd.
Fabric B	CHE-9803	1/4 yd.
Fabric C	CHE-9801	1/8 yd.
Fabric D	PE-430	3/8 yd.
Fabric E	PE-411	2/3 yd.

## CUTTING DIRECTIONS

### Body of Bag

- Cut One (1) 16" x 35" rectangle from Fabric **A**
- Cut One (1) 7" x 15" oval from Fabric **A**
- Cut One (1) 16" x 35" rectangle from Fabric **E** (Lining)
- Cut One (1) 7" x 15" oval from Fabric **E** (lining)

### Straps

- Cut Two (2) 4 1/2" x 33" rectangles from Fabric **D**

### Pockets

- Cut Two (2) 9" x 6 1/2" rectangles from Fabric **B**
- Cut Four (4) 3" x 6 1/2" rectangles from Fabric **C**

### Fusible

- Cut Two (2) 1 1/4" x 33" rectangles from Heavy Weight Fusible Interfacing
- Cut One (1) 16" x 35" rectangle from Lofty Fusible Fleece
- Cut Two (2) 7" x 15" oval from Lofty Fusible Fleece



CHE-8808  
Plummet Magnolia



CHE-9803  
Les Points Rose



CHE-9801  
En Route Sable



PE-430  
Moonstone

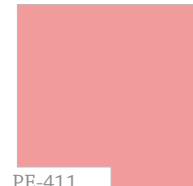

PE-411  
Quartz Pink

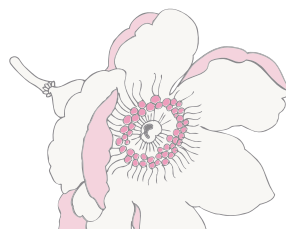
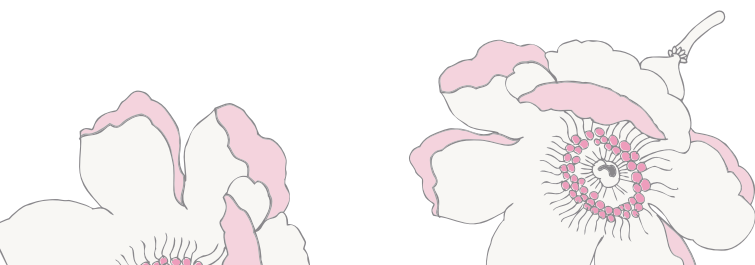



## BAG CONSTRUCTION

- Iron 16" x 35" Lofty Fusible Fleece rectangle to wrong side of 16" x 35" rectangle from fabric **E**.
- Iron 7" x 15" Lofty Fusible Fleece oval to wrong side of 7" x 15" oval from fabric **A**.
- Iron 7" x 15" Lofty Fusible Fleece oval to 7" x 15" oval from fabric **E**.

### Pockets:

- Fold sides and bottom of pocket (9" x 6 1/2" rectangle from fabric **B**) in 1/4" and iron folds.
- Fold top of pocket 1/4" iron fold.
- Fold top of pocket again at 3/4" and press.
- Top stitch top of pocket at 1/2". Repeat process for other pocket.

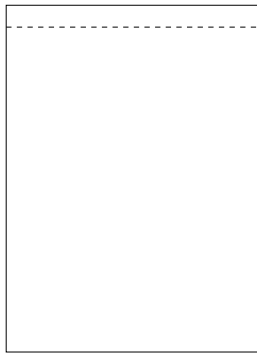

DIAGRAM 1

### Pocket Flaps:

- Sew two (2) 3" x 6 1/2" rectangles from fabric **C** at 1/4" seam allowance with right sides together.
- Sew all the way around the piece leaving a 1 1/2" hole.
- Pull right side of flap through the hole. Press unsewn section under. Repeat process for other flap.



DIAGRAM 2

### Positioning the Pockets:

- To position pockets measure 10 1/2" toward the middle of 16" x 35" rectangle from fabric **A**. Measure 5" down from the top of the rectangle and 2" up from the bottom. There should be roughly 3 1/4" in between each pocket.
- Top stitch pocket in place at 1/8", leaving the top open.

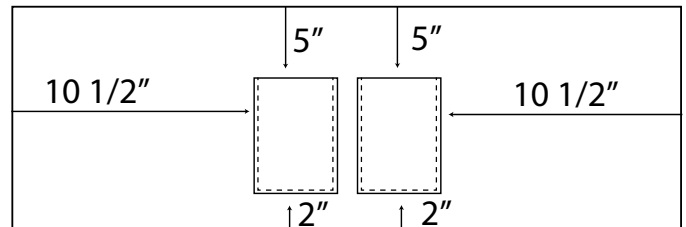

DIAGRAM 3

- Fold the flap under 1/4" on the side with the unsewn hole on it. Line up flap with top of pocket.
- Topstitch flap down at 1/8". Repeat with other flap.

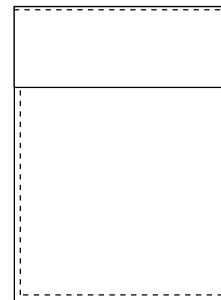

DIAGRAM 4

- Fold 16" x 35" rectangles from Fabric **A** in half and sew with right sides together. Repeat with 16" x 35" rectangle from fabric **E**.
- Press seam open.



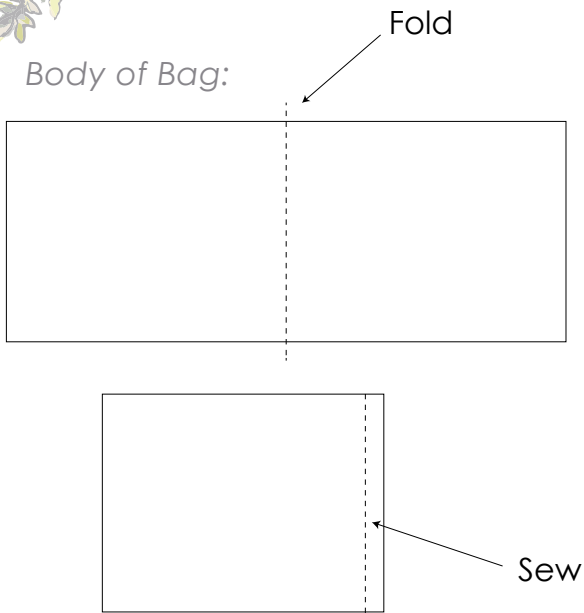
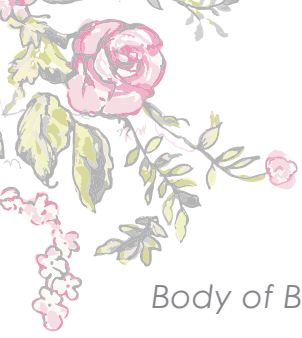

DIAGRAM 5

- Pin 7" x 15" oval from fabric **A** to the bottom opening out exterior of bag.
- Sew all the way around with right side together.
- Pin 7" x 15" oval from fabric **E** to the bottom opening of the lining of the bag.
- Sew all the way around leaving a 4" unsewn portion.

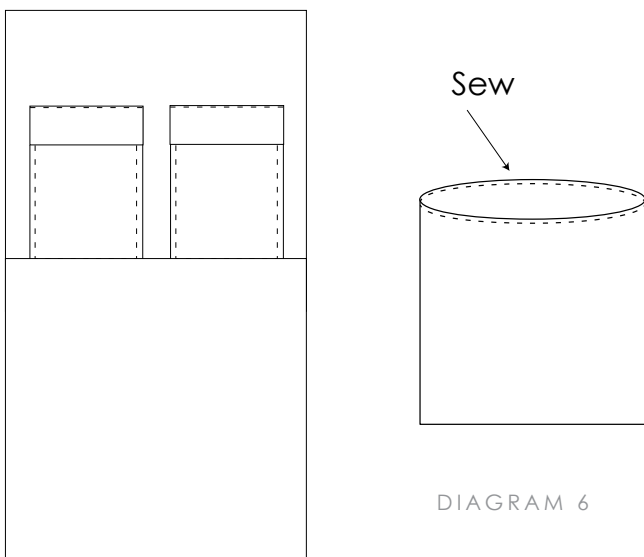

DIAGRAM 6

- Pull exterior of the bag through the unsewn hole in the lining. Hand stitch hole closed.
- Topstitch top of bag at 1/8".

*Straps:*

- Fold 4 1/2" x 33" rectangle from fabric **D** in half. Sew with right sides together.

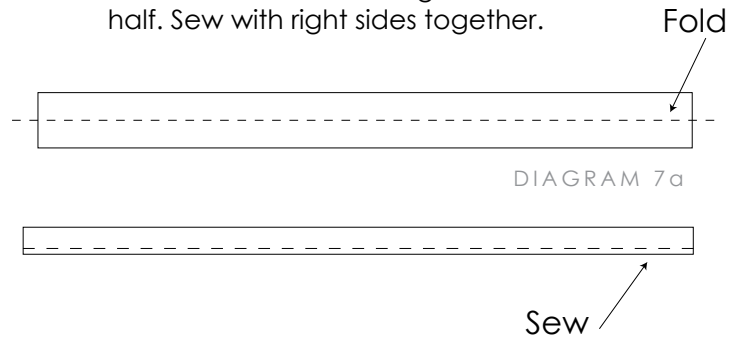

DIAGRAM 7a

DIAGRAM 7b

- Attach a safety pin to 1 1/2" x 33" rectangle from Heavy Weight Fusible Interfacing and inch it through the strap. Repeat for other strap.  
(Diagram 8a)
- Topstitch all sides of the straps at 1/4".  
(Diagram 8b)



DIAGRAM 8a



DIAGRAM 8b





- Place straps 3 1/2" in from the sides of the bag and 2 1/4" down from the top of the bag, with about 7 1/2" inbetween straps.
- For added detail and extra support for the handles, stitch a square with an X in the middle at each end of the strap to secure strap to bag.
- Attach straps to back of bag the same way.

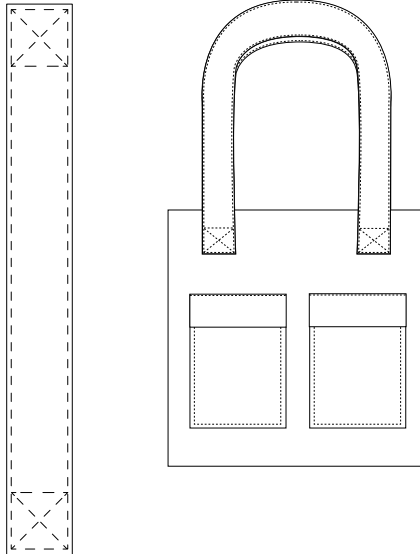

DIAGRAM 9



*Feel the difference*  
For more free patterns visit:  
[artgalleryfabrics.com](http://artgalleryfabrics.com)

*enjoy!*



NOTE: While all possible care has been taken to ensure the accuracy of this pattern, we are not responsible for printing errors or the way in which individual work varies.  
Please read instructions carefully before starting the construction of this quilt. If desired, wash and iron your fabrics before starting to cut.

Oval Template

7" x 15"

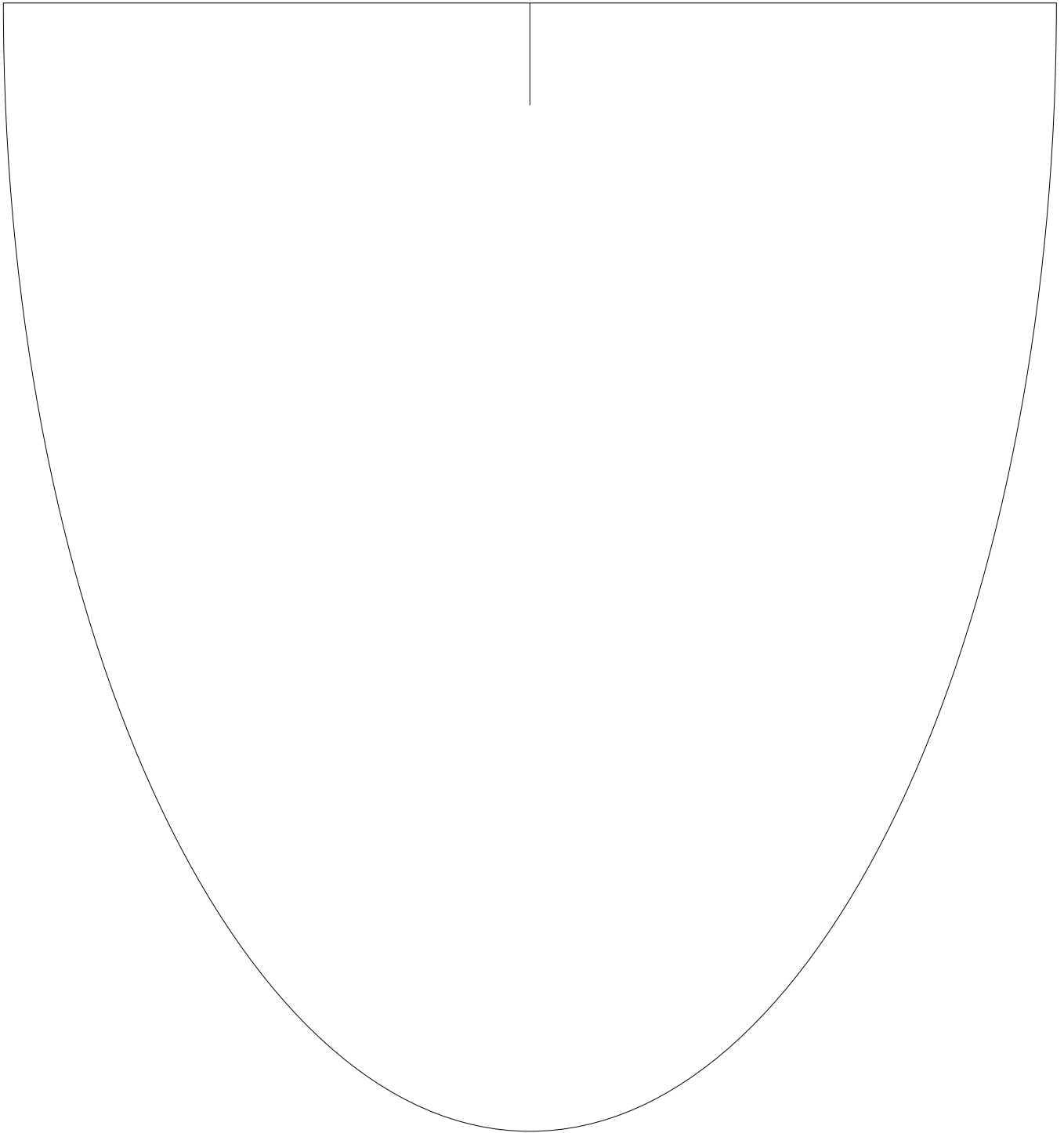

Line up notches and tape

Oval Template

7" x 15"

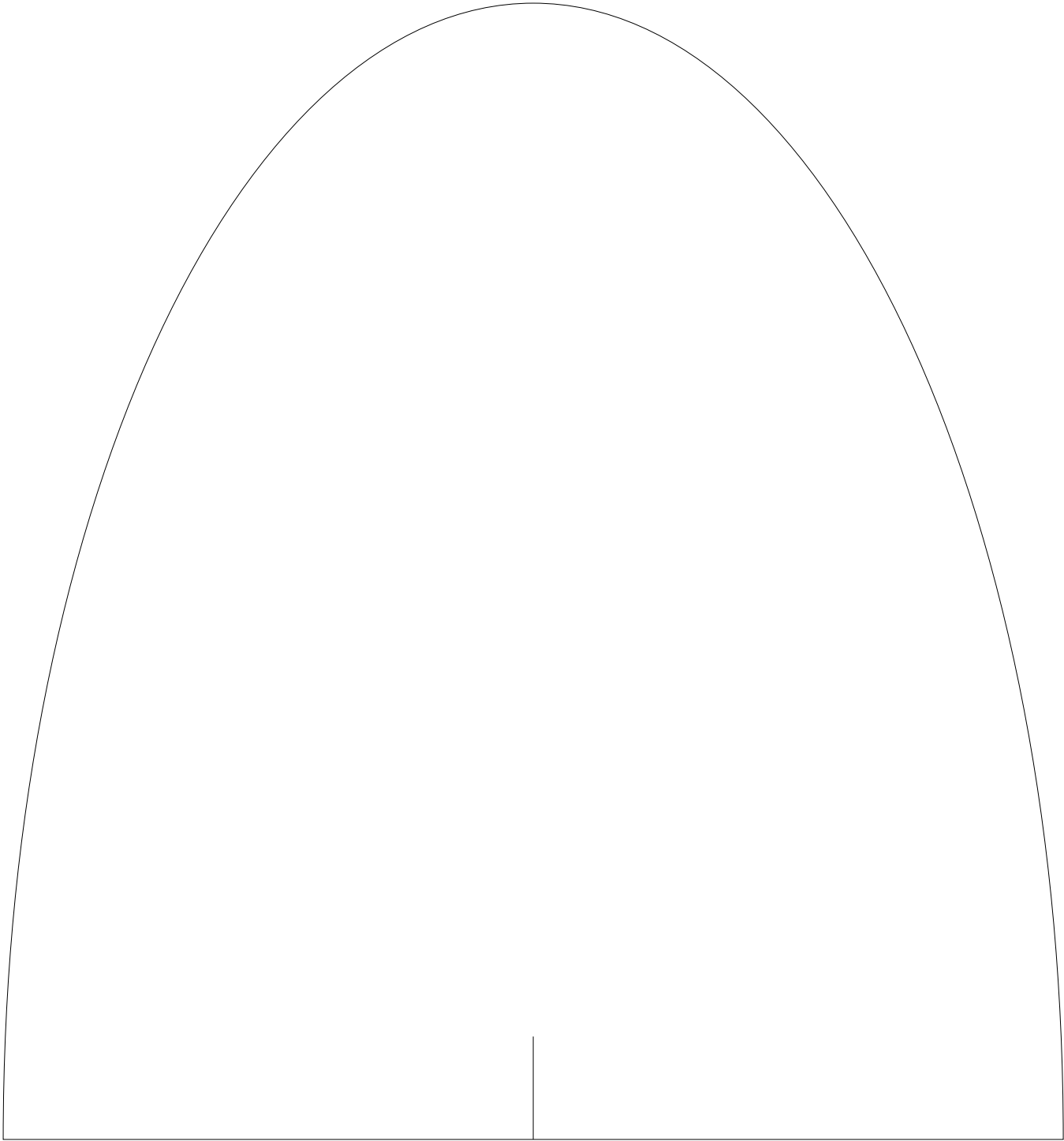

Line up notches and tape